

Powerful and efficient
with maintenance-free
AC drive motor

Sensitive lifting and lowering
with quiet, speed-controlled
hydraulic motor

High residual capacities
thanks to sturdy design
and four-wheel chassis

Easy, effortless steering with
electric tiller (optional)

Fast lifting of light loads
with LiftPlus (optional
up to 1.6 tonnes)



EJC 212/214/216/220

Electric pedestrian stacker (1,200/1,400/1,600/2,000 kg)

The EJC pedestrian stackers are designed for demanding applications. The trucks offer high lift heights and residual capacities, as well as long operating times. The powerful 3-phase AC drive motors combined with the Jungheinrich electronic controller guarantees high performance and minimum energy consumption. This ensures maximum throughput. The trucks also feature an outstanding level of user friendliness:

- Precise and sensitive lifting by electronically controlled lift motor. This allows easy stacking of heavy loads in narrow racking.
- Gentle depositing of the load on the floor or in the racking with proportional hydraulics.
- Minimum noise during lifting.
- LiftPlus (optional) enables the EJC 214/216 to achieve a significantly higher lift speed when lifting the forks with a light load (up to 400 kg) in comparison with the standard version.

- Electric tiller steering (optional) for minimum steering effort and therefore fatigue-free operation, in particular when travelling with the tiller upright (crawl speed mode).
- Numerous storage options ensure that pens, knives or documents are within easy reach.

As well as user friendliness, the truck offers excellent safety features: The long safety tiller in conjunction with the enclosed truck contours and the low apron ensure maximum operator safety.

The EJC draws its energy from batteries with capacities of up to 375 Ah. When required for multishift use, the EJC 212/214/216/220 offer battery compartments with lateral battery exchange as an option. A built-in charger (optional) ensures comfortable and reliable charging at any standard 13 Amp plug socket. Optional fast charging is available.

EJC 212/214/216/220

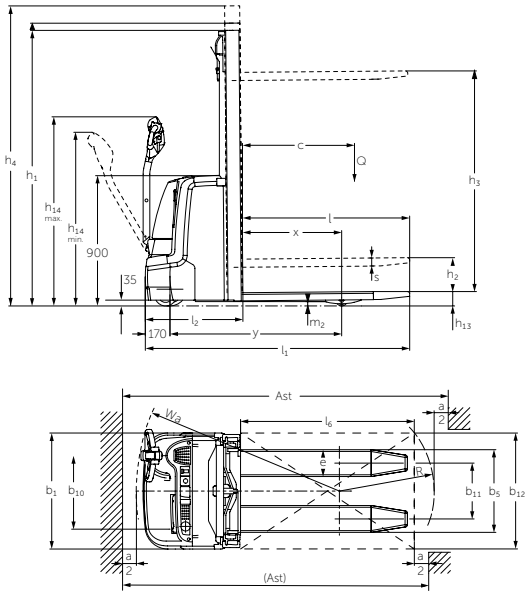

Standard mast types EJC 212/214/216/220													
	Lift h_3 (mm)	Lowered mast height ¹⁾ h_1 (mm)				Free lift h_2 (mm)				Extended mast height h_4 (mm)			
		EJC 212	EJC 214	EJC 216	EJC 220	EJC 212	EJC 214	EJC 216	EJC 220	EJC 212	EJC 214	EJC 216	EJC 220
Duplex ZT	2400	-	-	1750	-	-	-	100	-	-	-	2925	-
	2500	1750	1750	-	1950	100	100	-	100	2975	2975	-	3165
	2600	-	-	1850	-	-	-	100	-	-	-	3125	-
	2700	1850	1850	-	-	100	100	-	-	3175	3175	-	-
	2800	-	-	1950	2100	-	-	100	100	-	-	3325	3465
	2900	1950	1950	-	-	100	100	-	-	3375	3375	-	-
	3100	-	-	2100	-	-	-	100	-	-	-	3625	-
	3200	2100	2100	-	-	100	100	-	-	3675	3675	-	-
	3500	-	-	2300	2450	-	-	100	100	-	-	4025	4165
	3600	2300	2300	-	-	100	100	-	-	4075	4075	-	-
	3800	-	-	2450	-	-	-	100	-	-	-	4325	-
	4000	-	-	2550	-	-	-	100	-	-	-	4525	-
	4100	2550	2550	-	-	100	100	-	-	4575	4575	-	-
4200	-	-	2650	-	-	-	100	-	-	-	4725	-	
4300	2650	2650	-	-	100	100	-	-	4775	4775	-	-	
Duplex ZZ	2400	-	-	1700	-	-	-	1175	-	-	-	2925	-
	2500	1700	1700	-	1900	1225	1225	-	1235	2975	2975	-	3165
	2800	-	-	1900	2050	-	-	1375	1385	-	-	3325	3465
	2900	1900	1900	-	-	1425	1425	-	-	3375	3375	-	-
	3100	-	-	2050	-	-	-	1525	-	-	-	3625	-
	3200	2050	2050	-	-	1575	1575	-	-	3675	3675	-	-
	3500	-	-	2250	2400	-	-	1725	1735	-	-	4025	4165
	3600	2250	2250	-	-	1775	1775	-	-	4075	4075	-	-
	4000	-	-	2500	-	-	-	1975	-	-	-	4525	-
	4100	2500	2500	-	-	2025	2025	-	-	4575	4575	-	-
	4200	-	-	2600	-	-	-	2075	-	-	-	4725	-
4300	2600	2600	-	-	2125	2125	-	-	4775	4775	-	-	
Triplex DZ	3510	-	-	-	1850	-	-	-	1150	-	-	-	4210
	3990	-	-	1830	-	-	-	1298	-	-	-	4522	-
	4090	1845	1830	-	-	1338	1341	-	-	4597	4579	-	-
	4200	-	-	1900	2080	-	-	1368	1380	-	-	4732	4900
	4300	1915	1900	-	-	1408	1411	-	-	4807	4789	-	-
	4590	-	-	2030	-	-	-	1498	-	-	-	5122	-
	4690	-	2030	-	-	-	1541	-	-	-	5179	-	-
	4700	2050	-	-	-	1543	-	-	-	5212	-	-	-
	4800	-	-	-	2280	-	-	-	1580	-	-	-	5500
	5250	-	-	2250	-	-	-	1718	-	-	-	5782	-
	5350	-	2250	-	-	-	-	1761	-	-	5839	-	-

¹⁾ with 100 mm free lift

Technical data in line with VDI 2198

		Jungheinrich					
		EJC 212 ⁶⁾	EJC 214 ⁶⁾	EJC 216 ⁶⁾	EJC 220 ⁶⁾		
Identification	1.1	Manufacturer (short form)					
	1.2	Model					
	1.3	Drive	Electrics				
	1.4	Manual, pedestrian, stand-on, seated, order picker operation	pedestrian				
	1.5	Load capacity/rated load	Q t	1.2	1.4	1.6	2
	1.6	Load centre distance	c mm	600			
	1.8	Load distance	x mm	688 ⁴⁾	689 ⁴⁾	689 ⁴⁾	689 ⁴⁾
	1.9	Wheelbase	y mm	1256 ⁷⁾	1277 ⁷⁾	1277 ⁷⁾	1357
	Weights	2.1.1	Net weight incl. battery (see row 6.5)	kg	980	1039	1044
2.2		Axle load, w. load, front / rear	kg	740 / 1440	794 / 1645	814 / 1830	878 / 2329
2.3		Axle load, w.o. load, front / rear	kg	660 / 320	721 / 318	724 / 320	805 / 402
Wheels / chassis	3.1	Tyres	PU				
	3.2	Tyre size, at front	mm	Ø 230 x 70			
	3.3	Tyre size, at rear	mm	Ø 85 x 110	Ø 85 x 110	Ø 85 x 110	Ø 85 x 85
	3.4	Additional wheels (dimensions)	mm	Ø 140 x 54			
	3.5	Wheels, number front/rear (x = driven wheels)		1x +1/2	1x +1/2	1x +1/2	1x + 1/4
	3.6	Track width, front	b ₁₀ mm	507			
	3.7	Track width, rear	b ₁₁ mm	400			
Basic dimensions	4.2	Mast height (lowered)	h ₁ mm	1950	1950	1950	2100
	4.3	Free lift	h ₂ mm	100			
	4.4	Lift	h ₃ mm	2900	2900	2800	2800
	4.5	Extended mast height	h ₄ mm	3375	3375	3325	3465
	4.9	Height of tiller in drive position min. / max.	h ₁₄ mm	850 / 1305			
	4.15	Lowered height	h ₁₃ mm	90			
	4.19	Overall length	l ₁ mm	1887 ⁴⁾⁷⁾	1908 ⁴⁾⁷⁾	1908 ⁴⁾⁷⁾	1988 ⁴⁾
	4.20	Length incl. back of forks	l ₂ mm	737 ⁴⁾⁷⁾	758 ⁴⁾⁷⁾	758 / 838 ⁴⁾⁷⁾	838 ⁴⁾
	4.21	Total width	b ₁ /b ₂ mm	800	800	800	820
	4.22	Fork dimensions	s/e/l mm	56 / 185 / 1150	56 / 185 / 1150	56 / 185 / 1150	61 / 195 / 1150
	4.25	Width over forks	b ₅ mm	570			
	4.32	Floor clearance centre wheelbase	m ₂ mm	30	30	30	20
	4.33	Aisle width for pallets 1000 × 1200 sideways	Ast mm	2136 ³⁾⁷⁾	2149 ³⁾⁷⁾	2149 ³⁾⁷⁾	2229 ³⁾
4.34	Aisle width for pallets 800 × 1200 lengthways	Ast mm	2186 ²⁾⁷⁾	2199 ²⁾⁷⁾	2199 ²⁾⁷⁾	2279 ²⁾	
4.35	Turning radius	W _a mm	1474 ⁵⁾⁷⁾	1488 ⁵⁾⁷⁾	1488 ⁵⁾⁷⁾	1568 ⁵⁾	
Performance data	5.1	Travel speed, w. / w.o. load	km/h	6 / 6	6 / 6	6 / 6	5.3 / 5.4
	5.2	Lift speed, w. / w.o. load	m/s	0.13 / 0.22	0.16 / 0.25	0.16 / 0.25	0.1 / 0.18
	5.3	Lower speed, w. / w.o. load	m/s	0.43 / 0.37	0.37 / 0.34	0.37 / 0.34	0.37 / 0.34
	5.8	Max. gradeability, laden/unladen	%	8 / 16	8 / 16	8 / 16	5 / 16
	5.10	Service brake		generated			
Electrics	6.1	Drive motor rating S2 60 min.	kW	1.0 ¹⁾	1.6	1.6	1.6
	6.2	Lift motor, output at S3 (on time) 11 %	kW		3	3	3
	6.2	Lift motor, output at S3 (on time) 12 %	kW	2			
	6.3	Battery according to DIN 43531/35/36 A,B,C, no		no	no	no	B 43535
	6.4	Battery voltage/nominal capacity K5	V/Ah	24 / 300	24 / 300	24 / 300	24 / 375
	6.5	Battery weight	kg	243	243	243	288
6.6	Energy consumption according to VDI cycle	kWh/h	0.93	1.25	1.31	1.35	
Misc.	8.1	Type of drive control		AC SpeedControl			
	8.4	Sound pressure level at operator's ear according to EN 12053	dB (A)	62	63	63	63

¹⁾ 1.6 kW with option of electric steering

²⁾ Diagonal in accordance with VDI: + 138 mm

³⁾ Diagonal in accordance with VDI: + 214 mm

⁴⁾ DZ: x - 42 mm; l1 + 42 mm; l2 + 42 mm

⁵⁾ Tiller in upright position (crawl speed)

⁶⁾ Values for 290 ZT standard mast; 280 ZT and with battery as per line 6.5

⁷⁾ with battery compartment L (375 Ah) + 80 mm

Benefit from the advantages

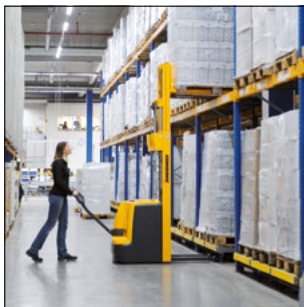

Precise and easy load stacking



Plenty of storage options to keep important items close to hand



Built in charger cable and plug

Intelligent control and advanced drive technology

Our motors use three-phase AC technology with electronic controllers perfectly optimised to your application offering more performance while reducing operating costs. Make use of these benefits:

- High efficiency with excellent energy management.
- Powerful acceleration.
- Fast direction change.
- Maintenance free AC drive motor.

Safe and comfortable stacking and retrieval

All lifting and lowering functions can be intuitively controlled using the multi-functional tiller arm. This allows the operator to concentrate fully on stacking and retrieving:

- Precise, gentle load lifting by speed controlled and noise-reduced hydraulic motor.
- Gentle depositing of loads using proportional hydraulics.
- Automatic reduction in speed with raised load.
- Four-wheel concept for maximum stability.
- LiftPlus (optional): The EJC 214/216 achieves a significantly higher lift speed with a light load (up to 400 kg).

Practical storage compartments

The EJC offers plenty of storage space for a tidy workplace:

- Paper storage in the top panel.
- Storage compartments in the dashboard.
- Clip pad.

Robust design

The EJC has been particularly robustly designed:

- One-piece, hot-rolled box section forks.
- Torsion-resistant mast with high residual capacities.
- Battery lid made of solid sheet steel.
- Front apron reinforced with additional beading and contouring.

Service-friendly technology

- Service access ports on the front of the chassis for fast tyre change.
- Castor wheel with bayonet mechanism for easy wheel change with the truck raised only slightly.
- Easy to install mast with screw connection.
- Tiller electronics are completely sealed to protect against humidity and dirt according to the IP65 standard.
- Electronic controller sealed according to IP54 protection.
- Built-in charger for the EJC 212 (optional) is protected against humidity and dirt according to the IP54 protection.

Long operating time

Large battery capacities and low consumption ensure long operating times. The built-in 24-V charger (optional) for wet cell batteries and maintenance-free batteries guarantees easy charging at any standard 13 Amp plug socket. This built-in charger in the EJC 212 is also available with a quick charging function for charging within a shift. The EJC 212 can also be used with the built-in charger in the cold store.

- Battery compartment M: 2 PzB 225 Ah/ 2 PzB 300Ah (EJC 212/214/216).
- Battery compartment L: 3 PzS 375 Ah.
- Lateral battery exchange (optional) for multi-shift use.

Additional equipment

- Tandem load rollers.
- Twin rollers for support wheel to reduce wear.
- CanDis: Discharge indicator and hour-meter.
- CanCode: Access control via PIN.
- Load guard.
- Gentle lowering of the load on the ground.
- Cold store version.
- Connection option e.g. for terminal, scanner or printer.

Jungheinrich UK Ltd.

Head Office:
Sherbourne House
Sherbourne Drive
Tilbrook
Milton Keynes MK7 8HX
Telephone 01908 363100
Fax 01908 363180

info@jungheinrich.co.uk
www.jungheinrich.co.uk

The German production facilities in Norderstedt and Moosburg are certified. **ISO 9001**
ISO 14001

Jungheinrich fork lift trucks meet European safety requirements.



JUNGHEINRICH
Machines. Ideas. Solutions.