

Powerful and economical
with maintenance-free
3-phase AC drive motor

Manoeuvrable and compact
with very short chassis

Sensitive lifting with
speed-controlled hydraulic motor

Comfortable working environment
with practical storage trays
for pens and documents

Fast, easy charging at any 13 Amp
socket with on-board charger
(optional)



EJC 110/112

Electric pedestrian controlled truck (1000 and 1200 kg)

The EJC range 1 pedestrian stackers show their strength in transporting over short distances and stacking or retrieving up to 3600 mm high. The compact chassis of the EJC ensures especially easy and safe operation even in the most confined spaces. Another useful feature is the option of driving in crawl mode with the tiller in upright position.

The combination of 3-phase AC drive motor and our own internally developed electronic controller ensures maximum

efficiency. The advantage is high speed and powerful acceleration with minimum energy consumption, which in turn ensures fast, efficient throughput.

Operators will also be pleased with precise lifting and gentle lowering (optional for EJC 110) of loads. The controlled lift motor and convenient keys on the tiller head allow the operator to stack loads to high heights, thereby lowering overall wear on material.

The power is supplied to the EJC 110/112 via batteries with capacities of up to 200 Ah. An on-board charger (optional) protected against moisture and dust ensures fast and easy charging at any 13 Amp plug socket. Optimal fast charging is available.

Practical storage compartments on the dashboard and front of the truck give you ready access to all the resources you need such as pencils, knives or documents.

EJC 110/112

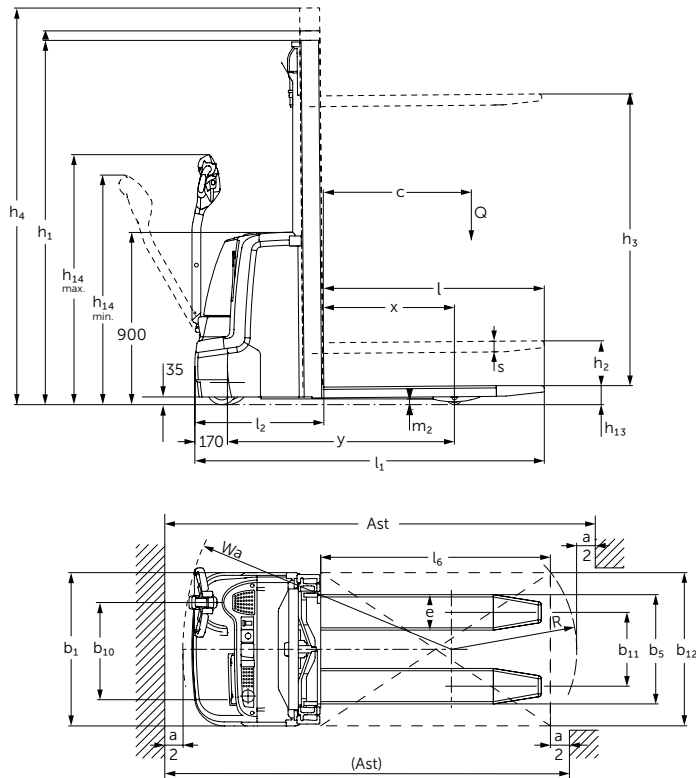

Standard mast types (mm)				
Designation	Closed height h_1^* mm	Free lift h_2 mm	Lift height h_3 mm	Extended height h_4 mm
EJC 110/112				
Two-stage mast ZT	1750	100	2500	2975
	1850	100	2700	3175
	1950	100	2900	3375
	2100	100	3200	3675
	2300	100	3600	4075
EJC 112				
Two-stage mast ZZ	1700	1225	2500	2975
	1900	1425	2900	3375
	2050	1575	3200	3675
	2250	1775	3600	4075

* ZT masts with 100 mm free lift

Technical data in line with VDI 2198

as at: 06/2012

Identification	1.1	Manufacturer (abbreviation)	Jungheinrich	Jungheinrich	
	1.2	Manufacturer's type designation	EJC 110¹⁾	EJC 112¹⁾	
	1.3	Drive	electric	electric	
	1.4	Operator type	pedestrian	pedestrian	
	1.5	Load capacity/rated load	Q (t)	1.0	1.2
	1.6	Load centre distance	c (mm)	600	600
	1.8	Load distance (Centre of load axle to fork face)	x (mm)	681	688
	1.9	Wheelbase	y (mm)	1184	1191
	Weights	2.1	Service weight incl. battery (see line 6.5)	kg	750
2.2		Axle loading, laden front/rear	kg	570/1180	650/1380
2.3		Axle loading, unladen front/rear	kg	510/240	580/250
Wheels, Chassis	3.1	Tyres		PU	PU
	3.2	Tyre size, front	mm	230 x 70	230 x 70
	3.3	Tyre size, rear	mm	77 x 75	85 x 110
	3.4	Additional wheels (dimensions)	mm	150 x 54	140 x 54
	3.5	Wheels, number front rear (x = driven wheels)		1x + 1/2	1x + 1/2
	3.6	Track width, front	b ₁₀ (mm)	507	507
	3.7	Track width, rear	b ₁₁ (mm)	415	400
Basic Dimensions	4.2	Closed mast height	h ₁ (mm)	1950	1950
	4.3	Free lift	h ₂ (mm)	100	100
	4.4	Lift (standard mast)	h ₃ (mm)	2900	2900
	4.5	Height, mast extended	h ₄ (mm)	3375	3375
	4.9	Height of tiller in drive position min./max.	h ₁₄ (mm)	850/1305	850/1305
	4.15	Height, lowered	h ₁₃ (mm)	90	90
	4.19	Overall length	l ₁ (mm)	1822	1822
	4.20	Length to face of forks	l ₂ (mm)	672	672
	4.21	Overall width	b ₁ /b ₂ (mm)	800/-	800/-
	4.22	Fork dimensions	s/e/l (mm)	56/185/1150	56/185/1150
	4.25	Width across forks	b ₅ (mm)	570	570
	4.32	Ground clearance, centre of wheelbase	m ₂ (mm)	30	30
	4.33	Aisle width for pallets 1000 x 1200 crossways	Ast (mm)	2071 ²⁾	2071 ²⁾
	4.34	Aisle width for pallets 800 x 1200 lengthways	Ast (mm)	2121 ³⁾	2121 ³⁾
	4.35	Turning radius	Wa (mm)	1402	1409
Performance Data	5.1	Travel speed, laden/unladen	km/h	6.0/6.0	6.0/6.0
	5.2	Lift speed, laden/unladen	m/s	0.12/0.22	0.13/0.22
	5.3	Lowering speed, laden/unladen	m/s	0.33/0.33	0.43/0.37
	5.8	Max. gradeability, laden/unladen	%	8/16	8/16
	5.10	Service brake		regenerative	regenerative
E-Motor	6.1	Drive motor rating S ₂ 60 min	kW	1.0	1.0
	6.2	Lift motor rating at S ₃ 10%	kW	1.7	2.0 ⁴⁾
	6.3	Battery acc. to DIN 43531/35/36 A, B, C, no		A/2 PzB	A/2 PzB
	6.4	Battery voltage, nominal capacity K ₅	V/Ah	24/200	24/200
	6.5	Battery weight	kg	185	185
	6.6	Energy consumption acc. to VDI cycle	kWh/h	0.83	0.93
Others	8.1	Type of drive control		AC	AC
	8.4	Sound level at the driver's ear according to EN 12 053	dB(A)	62	62

- 1) Values for standard mast 290 ZT
 2) Diagonal according to VDI + 212 mm
 3) Diagonal according to VDI + 137 mm
 4) for S₃ 12 %

This specification sheet according to VDI regulation 2198 only provides technical values for the standard truck. Non-standard tyres, different masts, additional equipment etc. could produce other values. Right reserved for technical changes and improvements.

Make use of the advantages

Innovative drive technology and controller

Our motors based on three-phase AC technology are perfectly optimised with the internally developed electric controller giving more performance while reducing operating costs. Make use of these benefits:

- High efficiency levels with excellent energy management.
- Powerful acceleration.
- Fast direction change.
- Maintenance-free drive motor.

Manoeuvrable and compact

With its compact chassis, the EJC is ideal for operating in confined areas. In addition you can continue working safely by pressing the crawl speed button with the tiller upright.



Good view of the load for precise positioning

Precise, safe stacking and retrieving

Stacking and retrieving of loads is especially safe, reliable and economical due to: Precise, sensitive load lifting with speed-controlled hydraulic motor.

- Gentle load depositing with two-stage lowering speed (EJC 110) and proportional hydraulics (EJC 112, optionally for the EJC 110).
- Long safety tiller provides a safe distance between the operator and the truck.
- Lift control system ensures less noise whilst lifting slowly.



Good storage options for pens, tools and documents

Practical storage areas

The EJC 110/112 provides excellent storage space for the operator:

- Paper storage on the chassis cover.
- Extra storage areas next to control panel.
- Clip board (combined with the optional metal cover).

Service-friendly technology

- Service access ports on the front of the chassis for fast tyre change.
- Wheel can be changed with the truck only slightly raised by using the castor wheel with a bayonet mechanism.
- Tiller electronics protected against moisture and dirt with IP65 protection.
- Electronic controller and built-in charger (optional) protected against moisture and dirt with IP54 protection.



Castor wheel is easy to replace, which lowers maintenance costs

Long duty cycle

- Battery capacities up to 200 Ah allow for long uptimes.
- On-board charger (optional) for easy charging at any 13 Amp socket (also available with quick charge function for rapid charging within one shift).

Optional equipment

- CanDis battery: discharge indicator and hour meter
- CanCode: access authorisation via PIN.
- Load backrest.
- Connection available for terminal, scanner or printer, etc.
- Especially sturdy metal battery cover for heavy-duty applications.

Jungheinrich UK Ltd.

Head Office:
Sherbourne House · Sherbourne Drive
Tilbrook · Milton Keynes MK7 8HX

Phone 01908 363100
Fax 01908 363180

info@jungheinrich.co.uk
www.jungheinrich.co.uk



Jungheinrich
Plants, Sales and
Services Europe
ISO 9001/ISO 14001

Jungheinrich trucks
conform to the European
Safety Requirements.



JUNGHEINRICH
Machines. Ideas. Solutions.